

# VAPOR LOCK CAUSE AND CURE

The following information has been compiled from extensive research and testing performed by Chevrolet Engineering and RV manufacturers concerning fuel handling problems of the Class A Motor Home (during 1982 and 1983). Chevrolet and the RV manufacturers examined typical "problem units" furnished by various owners in order to better understand "real-world" vapor lock problems in the highly customized Class A Motor Home and develop corrective actions.

This information is presented as an aid to the motor home owner in understanding the problems associated with vapor lock and their suggested solutions.

## Fuel System Plumbing

As determined from initial studies, Chevrolet engineers and RV manufacturing representatives determined that part of the problem concerning vapor lock involved the RV manufacturers' approach to the fuel system plumbing. Examination of problem units identified considerable plumbing errors, such as:

- Four feet of rubber hose added in the middle of the stretch chassis.
- A length of hose positioned over the top of the tank to the pickup.
- Total rubber plumbing which is tied to the rear hot water lines with zip straps so that there was a tendency for the fuel to boil and the lines to "suck shut" or kink at each zip strap.
- Vehicles equipped with a defective switch valve so that the ports did not line up properly and some of the valves would only switch occasionally. (Ports that did not line up caused restriction as did units that had two additional fuel filters and a stretch chassis. All of these factors add to the load on the mechanical fuel pump.)
- An electric fuel pump installed in the return line rather than the suction line.
- Incorrect tank cap venting.
- And so on.

Chevrolet and the RV manufacturers' representatives determined that 100 percent of the motor homes produced with plumbing errors such as those above could have vapor locking problems. Investigation showed that a properly plumbed fuel system down the inside of the frame rail was also not a 100 percent cure for the problem.

## Fuel Properties

As part of the investigation, Chevrolet Fuel and Lubrication Engineers conducted a nationwide survey examining the possibility that fuels could cause vapor lock. Results of the survey show that oil companies have contributed to the cause of vapor lock by the addition of alcohol to the fuel without informing the public or advertising the fuel as gasohol. Also, it was determined that butane was added to "cover up" lower grade crudes and to increase octane ratings. The result of the fuel being adjusted and the octane modifiers was a general increase in the Reid vapor pressure (RVP) of the fuels (the higher the Reid vapor pressure the greater the possibility of vapor lock). The average Reid vapor pressure of regular unleaded gasoline was 9.3 in 1980, 9.8 in 1981 and 10.3 in 1982 (with individual locations showing a reading of 12 and 13). With fuel changes toward the higher Reid vapor pressure fuels, some motor home owners who have never experienced any problems could have vapor lock problems that did not exist a year or so ago. Also, it was determined that mountains, steep grades and overloaded vehicles tend to aggravate the vapor lock problem, as recorded in a park survey at Pikes Peak. Vapor lock at Pikes Peak is the single most recorded mechanical problem encountered.

**NOTE:** GM's testing was performed under strict test procedures. The results are shown in Figure A7-7-1. The tests were performed on 10-lb. RVP fuel and 12-lb. RVP fuel. As shown on the charts, add the ratings after idle, after soak and 5-mile grade. The right-hand number on the charts indicates the overall rating. The higher the number the better the success rate.

## Results of Vapor Lock Investigation

During the week of October 17, 1983, Chevrolet invited all Class A Motor Home manufacturers to the GM Proving Grounds in Phoenix, Arizona. The purpose of this meeting was to discuss the findings of the investigation into the cause of vapor lock and to make specific corrective recommendations for current and future production vehicles (including changes in truck emissions). The meeting was attended by 34 of 36 RV manufacturers. Chevrolet suggested that the RV manufacturers incorporate the following recommendations into current and future vehicle building, as well as develop some adaptation for problem units already existing in the field. The following recommendations were presented:

- A one-half inch steel fuel line mounted on the outside of the frame rail, protected against rub and chafe (see Figure A7-7-2).

# VAPOR LOCK

## CAUSE AND CURE (Cont'd)

- An electric fuel pump mounted off the frame at the tank using an adjustable regulator set to 5 PSI at engine idle measured at the mechanical pump inlet (see Figure A7-7-2). Best success was obtained with the Holley Fuel Pump (No. 12-802) that includes a regulator and has ample volume for this engine (see Figure A7-7-3).
- The fuel requirements for the 454 engine at wide-open throttle are 25 gallons per hour at 2 PSI minimum and 3 PSI maximum. If fuel line lengths or routings create a situation where this cannot be met, an electric pump should be added at the fuel tank to supply fuel to the mechanical pump on the engine. Pressure in the supply line will further reduce the chance of bubbles forming versus a negative pressure situation with a mechanical pump only. (See Pressurized Fuel System Diagnosis Chart in Figure A7-7-7.)
- A single in-line filter should be placed between the tank and the electric fuel pump. (One filter choice is AC Part No. GF62C.)
- A 3/8-inch rubber fuel line connection should be made at the mechanical fuel pump and at the fuel pump sending unit.
- Power for the electric fuel pump should be controlled through a relay or special oil pressure switch to assure shut-down in the event of vehicle upset (see Figure A7-7-3). Consideration could be given to a manual priming override in the event the system has totally run out of fuel. Normal starts would occur with the fuel remaining in the carburetor and upon starting as oil pressure came up the special switch or relay and would turn on

the electric pump. (See installation instructions in Figure A7-7-4.)

Chevrolet invited all RV manufacturers to the Phoenix meeting to share the findings and test information, as it would be difficult for a singular RV manufacturer (or customer) to produce these tests on their own. Chevrolet informed the RV manufacturers that all necessary steps would be taken to correct any vapor lock problem on any chassis with a 137-, 158-, 178-inch wheelbase with a 100 percent factory system. As an additional commitment to the 1983 meeting, Chevrolet has informed all RV manufacturers that all necessary steps will be taken to correct any vapor lock problem for the 208-inch wheelbase Model CP32032 entering production for the 1988 model year with a 100 percent factory system. Additionally, Chevrolet requested that the RV manufacturers correct any field problems that are reported to them on any units that have been modified by the RV manufacturer — such as stretch chassis, dual tanks, dual fuel, oversize tanks, etc., as the individual manufacturers are more knowledgeable of their own systems and are in a better position to make their own modifications for the various models, years and options.

**NOTE:** Chevrolet has completed testing of a new 60-gallon tank. With the start of 1985 production, new fuel lines were installed on the outside of the frame rail. In the spring of 1985, a complete system was in production with in-tank electric pusher pump and external regulator adjustable by the RV manufacturer for an oversize wheelbase. (See Figure A7-7-5.)



## APPENDIX 7-7

# VAPOR LOCK CAUSE AND CURE (Cont'd)

### 1982 TESTING

Performance Rating Guide: 10 Excellent 8 Good 6 Fair 4 Poor 2 Bad

Test Condition:	SURGE DURING W.O.T.				
	R. V. P.	After Idle	After Soak	5-Mile Grade	Test Rating
Production lines with tank vent line and .055 restrictor.	12	5	4	4	13
Front section of fuel line outside frame. 3/8" from switching valve to pump.	12	8	7	4	19
Production lines with electric pump in-tank. No mech. pump.	12	4	4	Pressure dropped to '0'	8
Same, with mech. pump and elec. in-tank pump.	12	7	8	Pressure too high. Spewed badly above 5-6 PSI at carb.	15
3/8" outside frame, full length	10	8	6	10	24
Same as above except R. V. P.	12	8	7	5	20
1/2" outside frame, 3/8" at ends. Full length	10	5	10	10	25
Same as above except R. V. P.	12	6	6	6	18
Production fuel lines, booster pump installed. Pressure set at 4 lbs., at booster pump @ WOT Holley # 12-802	10	10	8	10	28
Same as above except R. V. P.	12	6	8	5	19
Aux. tank, production lines.	10	10	5	5	20
Same as above except R. V. P.	12	4	4	4	12

Figure A7-7-1 — Payson Grade Test — 1982 Test Results

**NOTE:** As indicated on the chart for the 5-mile grade, the pressure dropped to 0 and on another occasion pressure was too high and fuel spewed badly. The Rochester carburetor can operate from 1-1/2 to 5 lbs. of pressure. It is possible to starve the engine as well as to overshoot with too much pressure which would provide evidence as to why many add-on electric pumps have not been successful and have often created a second problem.

# VAPOR LOCK CAUSE AND CURE (Cont'd)

1983 TESTING

Performance Rating Guide: 10 Excellent 8 Good 6 Fair 4 Poor 2 Bad

FULL LINE CONFIGURATIONS		10# FUEL					
Regulator at Rear	Mech. Pump	Elec. Pump	Reg'ltr at 4 PSI	Reg'ltr at 5 PSI	Rating/Min.	Comments	Test No.
3/8" Inside Full Length	X		10# Fuel		4/34	w/Filter & Shielded Lines	5
3/8" Inside 1/2" Outside Front	X				4/36	w/Filter & Shielded Lines	6
12# FUEL							
3/8" Inside RR Outside Front	X	X		X	7/60	w/Filter & Shielded Lines	39
3/8" Outside Full Length	X	X		X	4/35	w/Filter in line STD Location	40
.5" Outside Full Length	X				4/18	w/Carb. Filter No Filter Inline	30
"		X	X		3/8	w/Carb. Filter No Filter Inline	31
"	X	X	X		6/60	w/Carb. Filter No Filter Inline	32
"	X	X		X	10/60	w/Carb. Filter No Filter Inline	33
"		X		X	4/18	w/Vapor Return Fuel Filter	38
"	X	X		X	7/60	w/Filters '84 Proposed	43
"	X	X		X	8/60	w/o Carb. Filter '84 Proposed	44
"	X	X		X	4-5/60	Same as '44 Only Red Elect. Pump	46
"		X	X		4/18	No Filter	35
"		X		X	4/18	No Filter	36
"		X		X	4/30	w/Vapor Return Fuel Filter	37
3/8" Inside Shielded to 3/8" Outside		X	X		4/35	w/Vapor Return Filter-Merrit	41
"		X		X	4/36	"	42
"		X		X	4/24	Merrit-w/Red Low Pres. Pump	45

Figure A7-7-1 (Continued) — 1983 Test Results — 10-lb. and 12-lb. RVP Fuel

# VAPOR LOCK CAUSE AND CURE (Cont'd)

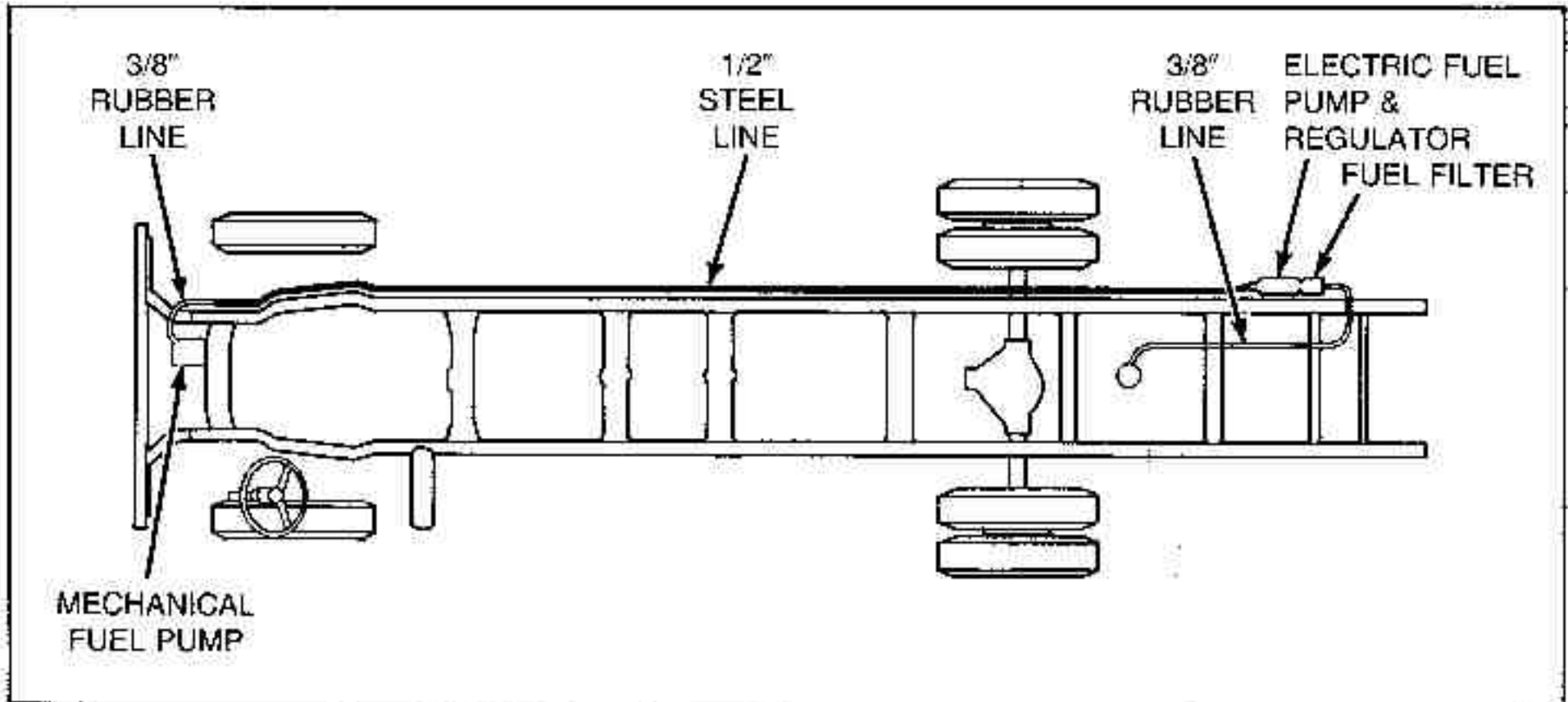
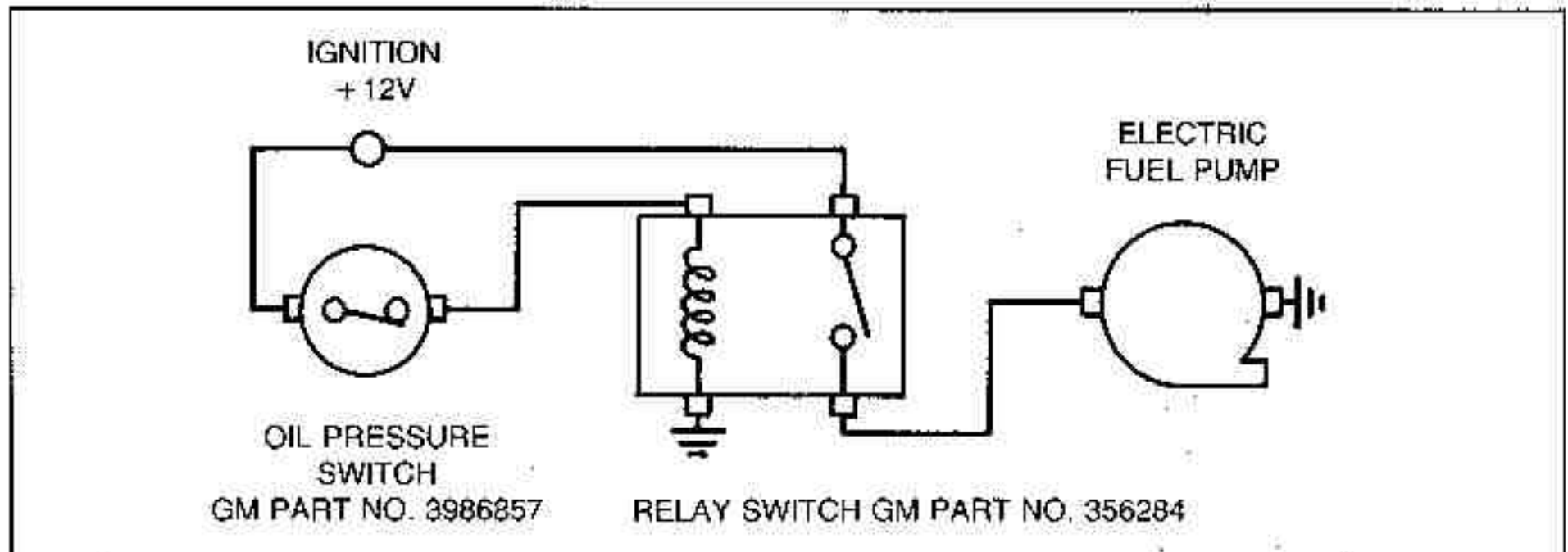

Figure A7-7-2 — 1984 Recommended Field Fix



**NOTE:** THE FOLLOWING OIL PRESSURE SWITCHES CAN BE USED WITH OR WITHOUT A RELAY SWITCH AND ARE CAPABLE OF HANDLING CURRENT DRAW REQUIREMENTS OF THE HOLLEY GPH 110 (PART NO. 12-802) MAX-PRESSURE PUMP.

GM PART NO.	CONNECTION
25025259	1/8 - 27 DRYSEAL (NPTF)
457874	1/8 - 27 DRYSEAL (NPTF)
14034354	1/4 - 18 DRYSEAL (NPTF)

CONNECTOR 12004275 WITH LOCK 12010259 CAN BE USED AS THE ELECTRICAL CONNECTION FOR EACH OF THESE SWITCHES.

HOLLEY ALSO PRODUCES A SWITCH (PART NO. 12-810) THAT DOES NOT REQUIRE A RELAY.

Figure A7-7-3 — Electric Fuel Pump/Oil Pressure Switch Relay

# VAPOR LOCK CAUSE AND CURE (Cont'd)

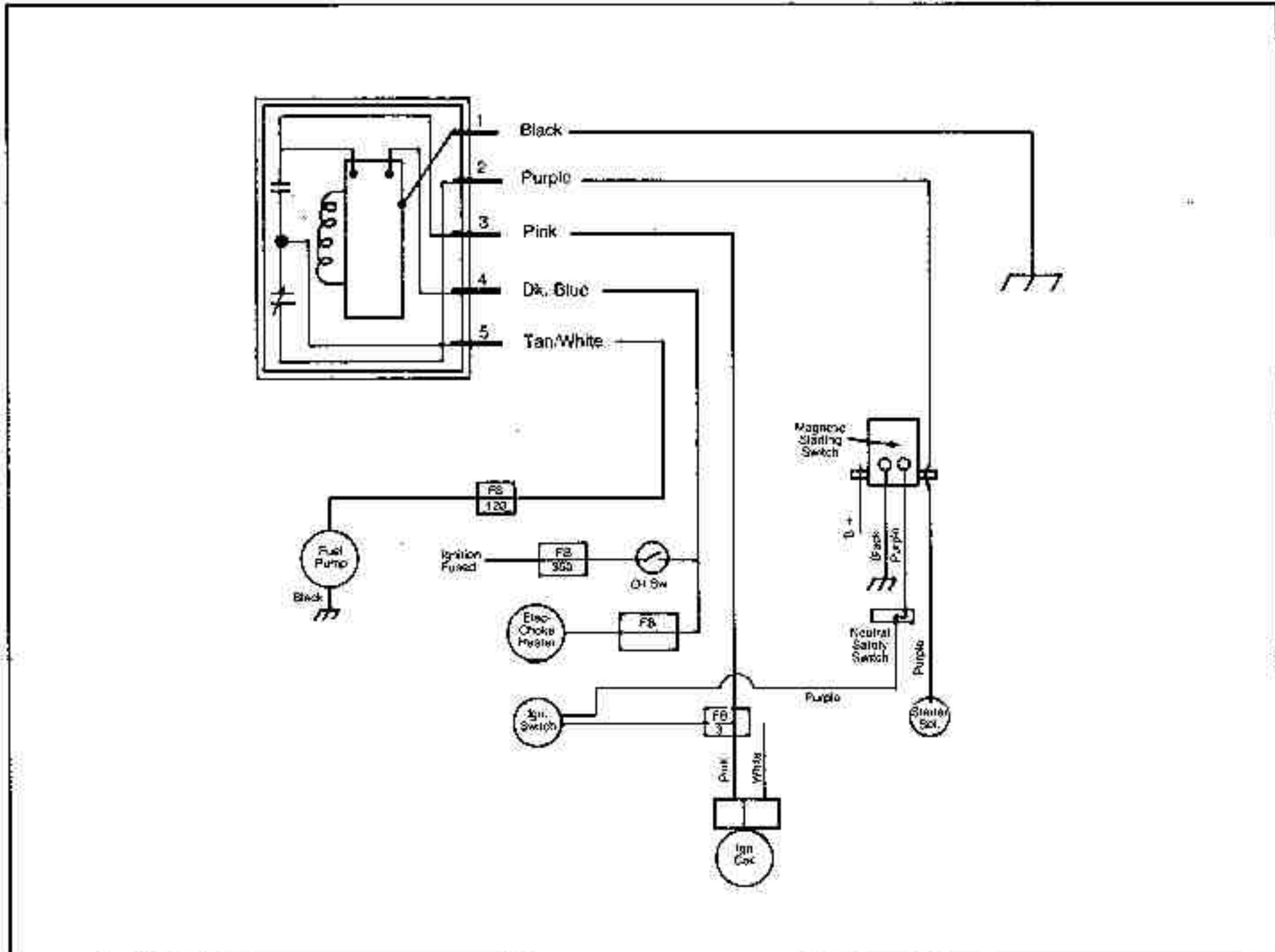

Figure A7-7-6 — Engine Electrical Fuel Pump Relay — Typical Wiring Diagram

**NOTE:** Without activation of the electric in-tank fuel pump, the chances for a vapor lock in the system increases because of the increased workload on the mechanical pump through the electric pump. To check the system, perform the following operational test. Turn the ignition key to the RUN position. Have an assistant check (listen/feel) the tank end for pump operation as a capacitor charges in the relay. The pump will run for approximately five seconds after the key has been turned. (Twelve volts is also supplied to the pump in the crank position and as the engine starts and oil pressure builds, 12 volts is supplied to the electric fuel pump whenever the engine is running.)



## APPENDIX 7-7

# VAPOR LOCK CAUSE AND CURE (Cont'd)

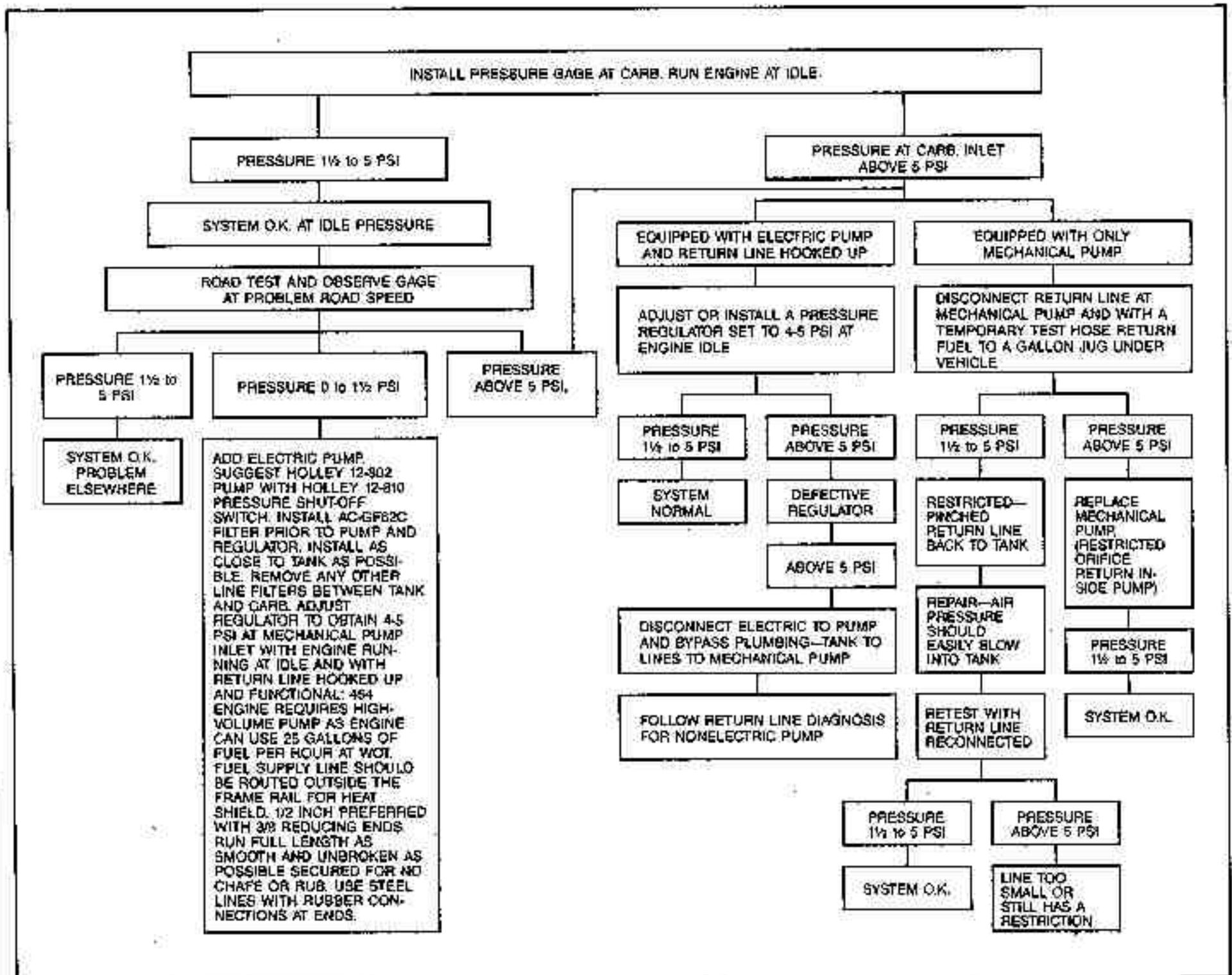

Figure A7-7-7 — Pressurized Fuel System Diagnosis Chart

**NOTE:** Cool fresh air should be introduced through the fresh air induction via hose from the front of the radiator to the carburetor air cleaner snout. This has proven effective in reducing fuel percolation in the carburetor fuel bowl.